

Tech-Net Notes

“Fixed Right – First Time”

Volvo Technicians, Service and Parts Managers

NO: 43-37
DATE: 2-25-2003
MODEL: MY 2001-2002 S60, V70, V70 XC
SUBJECT: Shift Quality Issues due to B4 Servo Cover Failure,
2-3 upshift harshness or flare
CHASSIS: These chassis breaks are approximate:
S60: 062000-152000
V70: 116000-230000
V70 XC: 036000-067100

TRANSMISSION SERIAL NUMBER: The first 3 digits of the serial number on the affected transmissions will be between 01C (March 2001) and 01L (December 2001).

DESCRIPTION:

In the AW 55-50, brake number four (B4), is only applied in 3rd gear. The B4 is applied by a piston, which is covered by an aluminum cap. This cap has a steel washer crimped to its inside surface, and a rubber cushion that sits between the cover and the washer.

If this washer breaks free from the crimps it will become concaved because of the B4 piston return spring pressure.

This loose washer can cause:

- 2-3 upshift flare / slip
- Harsh 2-3 upshifts
- 3-4 upshift flare / slip
- Harsh 4-3 downshifts

Replacing the broken B4 cover with a new one (PN 30651771) will remedy these symptoms.

SERVICE:

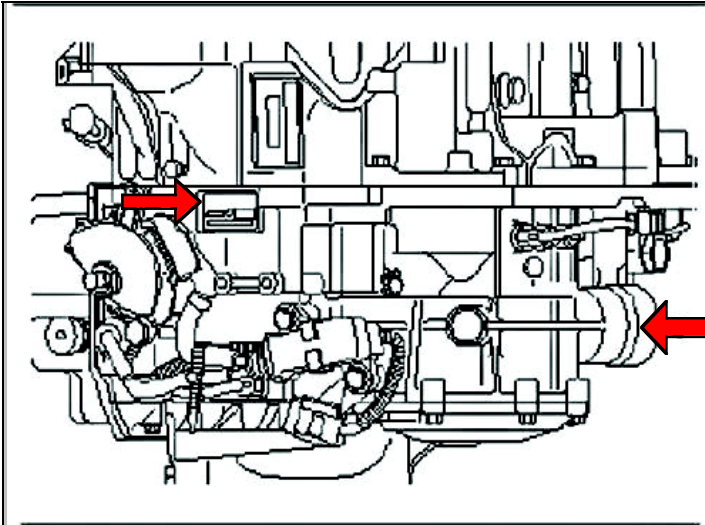

1. Location: This is a top view of the transmission, as seen from under the hood. The B4 cover is located on the rear of the transmission. It faces towards the rear of the car.

The B4 cover and the identification plate, which contains the serial number are highlighted in this drawing.



2. Preparation: Allow the car to cool. This will make the cover easier to remove, as it tends to get stuck if the transmission is hot. Also, this will allow you to do some adaptation while the transmission is still cold.

Remove the LF wheel and the splash pan for access.



3. Cleaning: Clean the area so that no foreign material will enter the transmission (This view is from below the car).

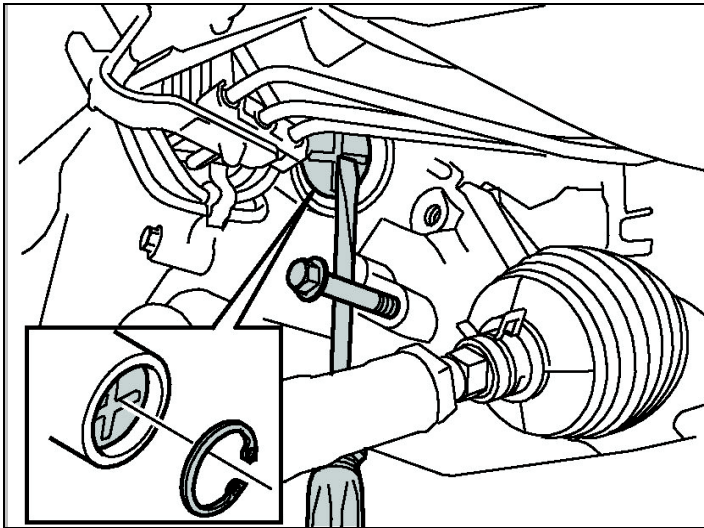

4. Removal: Install a bolt (M10X80, PN 968808) in the transmission case as shown. Using a heavy screwdriver or pry-bar, push on the cover a few times. This will loosen up the cover and make the snap-ring easier to remove.



5. Remove the snap-ring.

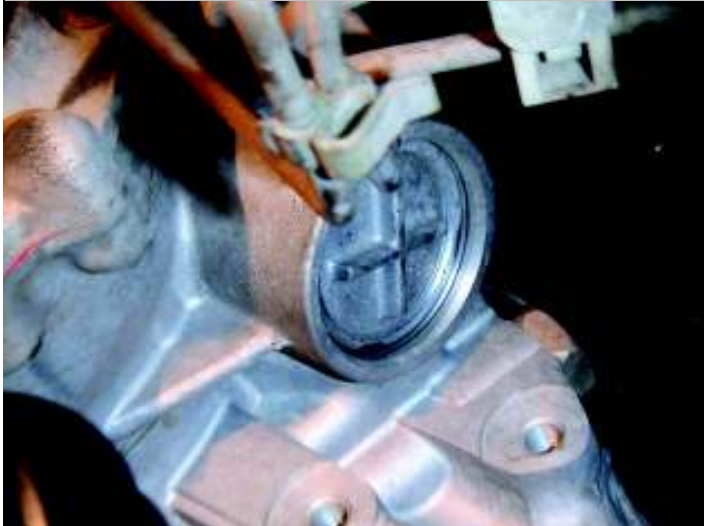

6. The cover is a tight fit, so it will usually stay in the transmission even after the snap-ring has been removed.

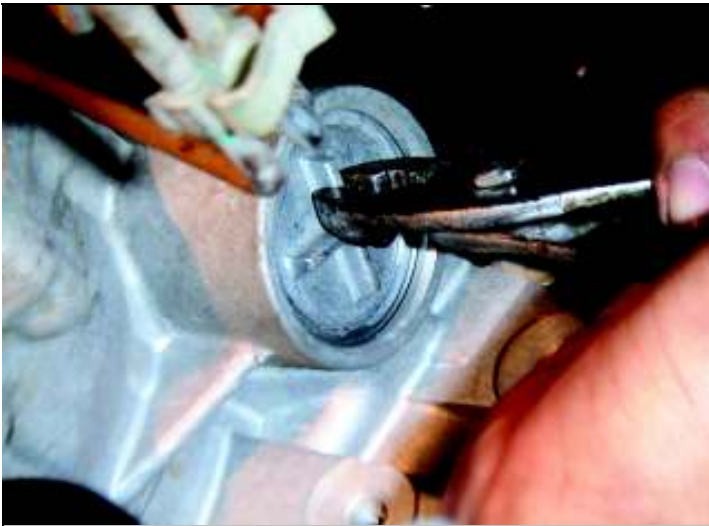

7. Gently twist the cover so that it rotates a bit in its bore. Once it is free, it will easily come out of the transmission case.



8. Remove the servo cover from the transmission. If it is faulty, it will look like the one pictured here. The steel washer will have become separated from the aluminum cover. As pictured here, the piston and spring will usually stay inside the transmission. If the piston begins to slide out, push it back in and it will usually stay in place.

Note: If the steel washer is still firmly attached to the aluminum cover, re-install it according to the rest of the procedure, it is not the cause of the harshness / flare.



9. Install two of the O-rings from the kit (PN 30651771) onto the new cover. Lubricate the O-rings with transmission fluid.

Check the groove for the snap ring in the transmission case for sharp edges. Remove any sharp edges with fine emery cloth and clean the area.

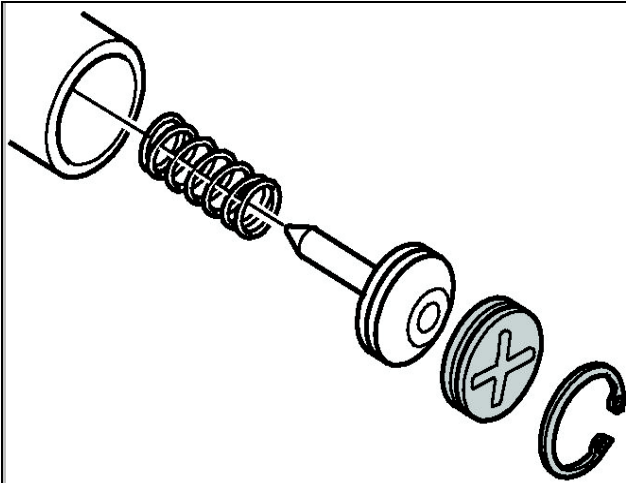

10. Installation: If the piston and spring do come out of the transmission, clean them with transmission fluid and re-install them with the new cover as shown here. Be careful not to drop the piston. If it does fall, check it carefully for damage. If necessary, the piston O-ring can be replaced with the third one included in the kit. You can not replace the piston with one from another transmission; several different length pistons are used when the transmission is calibrated and assembled.

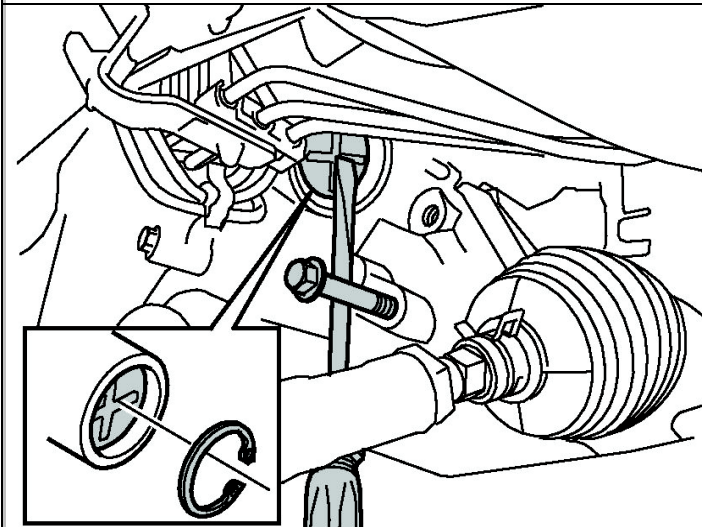

11. Once the new cover is placed in the bore, push it in using the bolt and screwdriver (this is to compress the spring). Install the new snap-ring and be sure it is properly seated in the groove.



12. Remove the bolt, clean up any spilled oil, re-install the splash pan and the LF wheel.

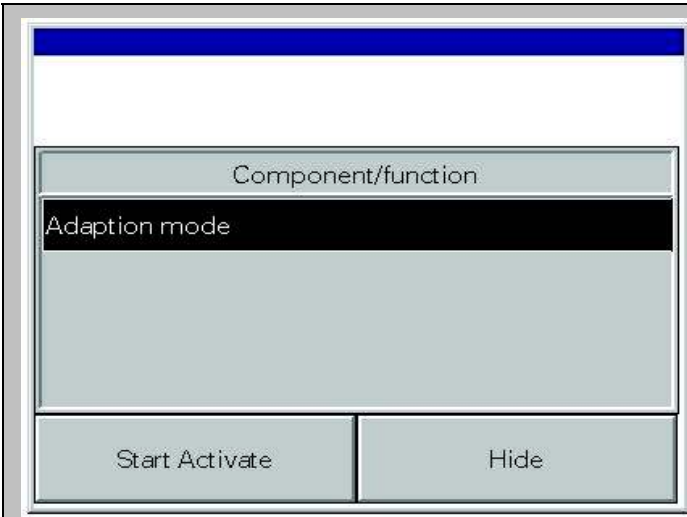

13. Adaptation: Because this repair only affects 3rd gear, **there is no need to "Reset Adaptation to Zero"**. Start the car and let it idle in 'P'. Using the Vehicle Communication section in VADIS, activate Adaptation Mode. Ignore the instruction to warm up the transmission first. When you successfully activate Adaptation Mode, the message "Operation Done" will appear in the grey box in VADIS. The text message "Transmission oil temperature too high" and the confirmation triangle will not appear until the oil reaches 65° C.



14. Begin driving the car right away, with steady throttle openings, even now while it is cool. Continue to perform 2-3 upshifts at various throttle openings until the shift quality is acceptable.

Note: This may be difficult at first, because some air has entered the system during the repair. Using higher throttle opening and manually shifting 2-3, 3-4, 4-3, 3-2 will help remove this air.

Then perform several 4-3 coast-downshifts and confirm that the shift quality is acceptable. Once the oil temperature has exceeded 65° C the triangle will flash each time you have a 'Perfect Shift'. Check the fluid level and confirm there are no leaks before returning the car to the customer.

WARRANTY CLAIM INFORMATION

LABOR OP	LABOR DESCRIPTION	LABOR TIME
43908-2	B4 Servo Cover Replacement	.7

Claims may be submitted under the New Car Warranty when there is a documented customer complaint using claim type: 01

VOLVO for life,
Volvo Cars of North America, Inc.
Technical Service

Please read, initial and circulate:

____ Svc Mgr ____ Parts Mgr _____ TECHS

____ Wty Administrator