

Brief description

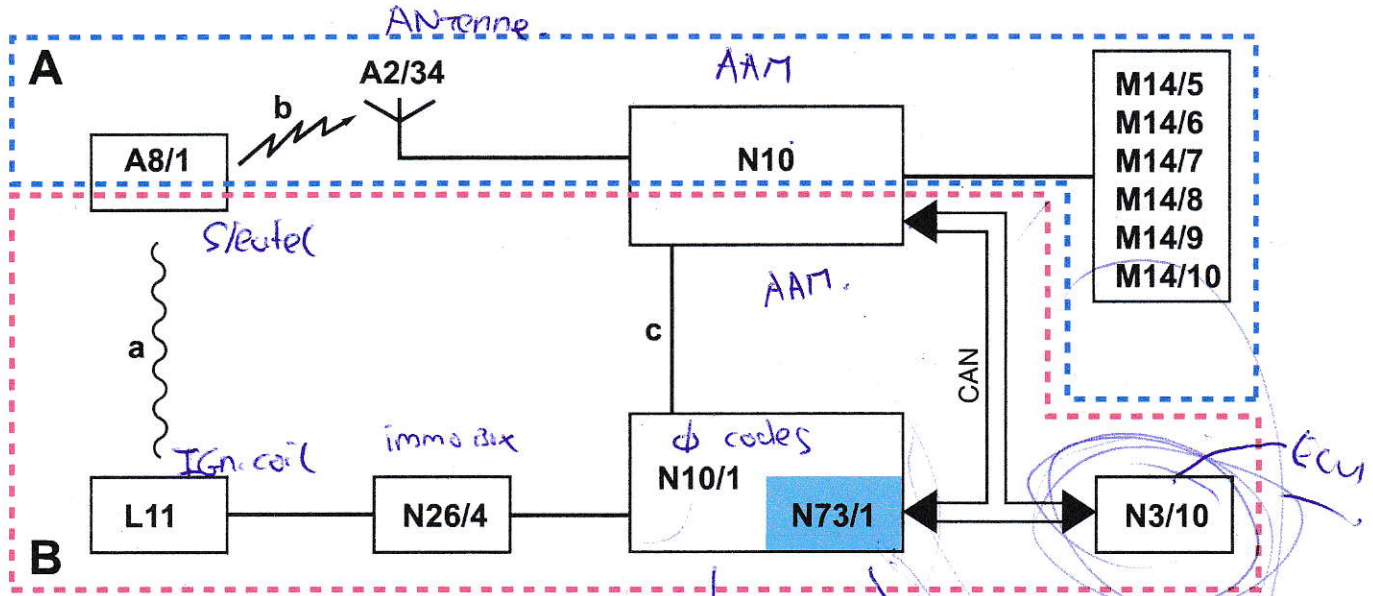

Illustration of the principle (gasoline engine)

A2/34	Central locking antenna
A8/1	Transmitter key
L11	Transponder coil
M14/5	Right front door central locking motor
M14/6	Left front door central locking motor
M14/7	Rear-end door central locking motor
M14/8	Left rear door central locking motor
M14/9	Right rear door central locking motor
M14/10	Fuel filler flap central locking motor
N3/10	ME-SFI [ME] control unit
N10	All Activity Module (AAM)
N10/1	Extended Activity Module (EAM)
N26/4	Mercedes-Benz immobilizer
N73/1	DAS control unit

CAN Controller Area Network

A	Access authorization
B	Drive authorization
a	Inductive signal
b	Radio signal
c	Wake-up signal